



FOODCYCLER™ USER MANUAL





WELCOME TO YOUR CLEANER, GREENER HOME

The FoodCycler™ is an energy-efficient food recycler which transforms your leftovers and food scraps into a nutrient-rich soil amendment. The aerobic process reduces food waste by up to 90% of its original volume, leaving a garden-ready supplement that is scientifically proven to nourish your garden.

This guide will familiarize you with your FoodCycler™, introduce you to its features and functions, while also showing you how to use and care for your unit.

To ensure that you are using your unit safely and effectively, please read this guide thoroughly prior to operating your new unit. Please be advised that this unit is designed for home and office use only.

CONTENTS

SAFETY GUIDELINES	1
SPECIFICATIONS	2
PARTS	3
UNIT SETUP	4
RUNNING A CYCLE	5
REPLACING YOUR CARBON FILTERS	7
WHAT CAN BE CYCLED?	8
USING YOUR BY-PRODUCT IN THE GARDEN	9
FAQ	11
INDICATOR LIGHTS GUIDE	14
TROUBLESHOOTING GUIDE	17

IMPORTANT SAFEGUARDS

⚠ WARNING

This appliance is intended for household use and other locations where small amounts of food waste are generated.

The FoodCycler™ is a Household Electric Appliances product.

Basic safety instructions should always be followed when handling electrical appliances. This includes the following:

- Carefully read all instruction materials accompanying the product.
- To avoid electrical shocks, keep cords, plugs and portable electrical appliances away from water and other liquids.
- Turn the appliance OFF, then unplug from the outlet when not in use, before assembling or disassembling parts and before cleaning. To unplug, grasp the plug and pull from the outlet. Never pull from the power cord. Permanently Installed - Make sure appliance is OFF when not in use, before putting on or taking off parts, and before cleaning. Allow the unit's interior components to cool before handling. Avoid touching moving parts.
- Do not operate any appliance with a damaged cord or plug or after the appliance malfunctions, or is dropped or damaged in any manner. Contact the manufacturer at their customer service telephone number for information on examination, repair, or adjustment. (Domestic customer service telephone number must be stated in the instruction manual, literature contained within the product's packaging or permanently marked on the appliance).
- The use of attachments not recommended or sold by the manufacturer may cause fire, electric shock, or injury.
- Do not operate the machine outdoors if the unit is at all exposed to the elements.
- Do not operate at or store in below freezing temperatures
- Do not let electrical cord hang from counter or table edge.
- Unit must only be plugged into properly grounded outlets
- Do not touch any hot surfaces. Use the handles or knobs provided for safe handling.
- Do not place the unit on or near a hot gas or electric burner.
- Do not use appliance for any purpose other than its intended use.
- Do not dismantle, reconfigure, alter or adapt the unit in any way.
- Do not immerse the unit in water or liquids of any kind.
- Do not put hands or any materials other than food waste inside the unit during operation to reduce the risk of injury to persons, or damage to the mechanism.
- This appliance is not intended for use by persons (including children) with reduced physical, sensory, or mental capabilities, or lack of experience and knowledge, unless they are closely supervised and instructed concerning use of the appliance by a person responsible for their safety. Close supervision is necessary when any appliance is used by or near children. Children should be supervised to ensure that they do not play with the appliance.

SAVE THESE INSTRUCTIONS

SPECIFICATIONS

PRODUCT NAME	FoodCycler FC-30
MODEL NUMBER	FC-30 / FC-30E
PROCESSING MODE(S)	Drying, Grinding, Cooling
MAX WATTAGE	500W
POWER INPUT (FC-30)	110-120V 60 Hz
POWER INPUT (FC-30E)	220-240V 50/60Hz
ENERGY USAGE (RUNNING)	App. 0.8 kWh per cycle
ENERGY USAGE (STANDBY)	2 kWh per month
PROCESSING TIME	4-8 hours
CAPACITY	< 2.5L
WASTE VOLUME REDUCTION	80-90%
COLOR	Grey
WEIGHT (OUT OF BOX)	19 lbs, 13 ounces (9 kgs)
DIMENSIONS (OUT OF BOX)	(W)11" x (D)12.6 x (H)14.2" ("28cm x 32cm x 36cm)

PARTS

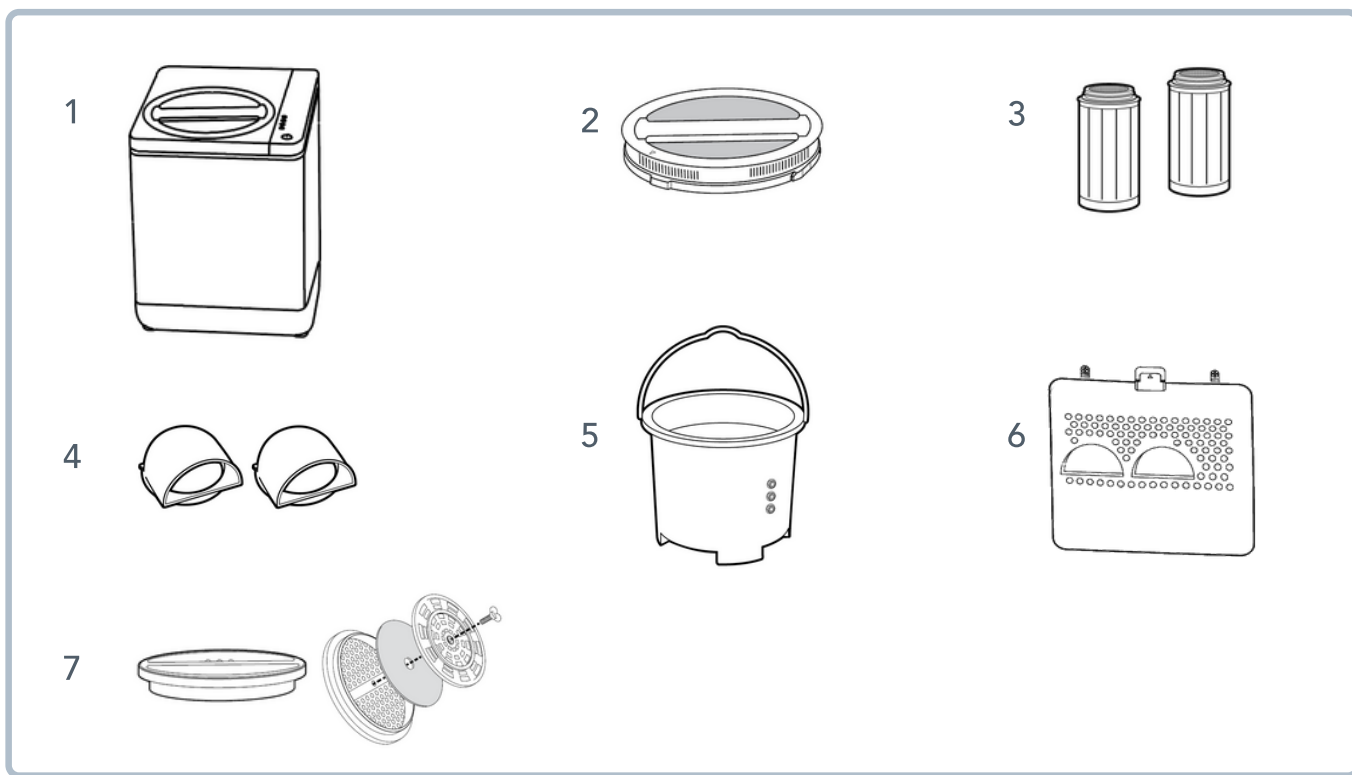

Each one of these parts forms the complete FoodCycler system. Your FoodCycler will be shipped with the waste bucket, carbon filters and lid in their correct placement inside the unit. The filter caps are located inside the unit, in the bucket. Remove the filter caps and install on filters prior to cycling.

- 1 FoodCycler™
- 2 FoodCycler™ unit lid
- 3 Carbon filters
- 4 Filter caps
- 5 Removable waste bucket
- 6 Unit back panel
- 7 Bucket lid with deodorizing carbon filter liner

UNIT SETUP

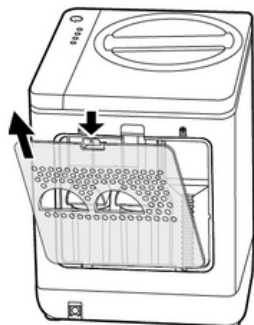

1. Open unit's back panel.

Detailed instructions: Grip the plastic tab (with the arrow) at the top of the back panel. Pull down gently on tab to release the back panel from unit.

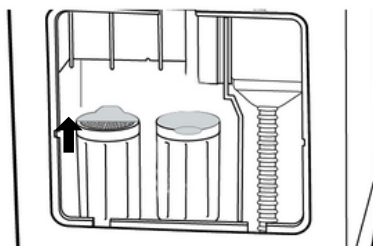

2. Peel off filter stickers, if applicable*

*Note: Not all units come with filter stickers in place. If you do not see the white plastic stickers, then they have already been removed prior to leaving the manufacturer.

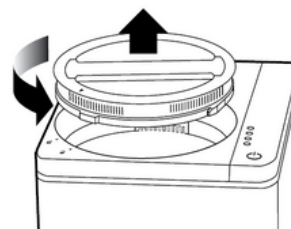

3. Open unit lid.

Detailed instructions: To open the lid, turn the lid counterclockwise until the arrow on the bucket lid is facing the unlock symbol on the side of the unit.

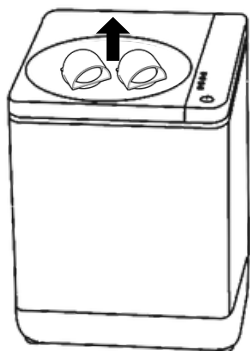

4. Remove filter caps from inside the unit's removable bucket.

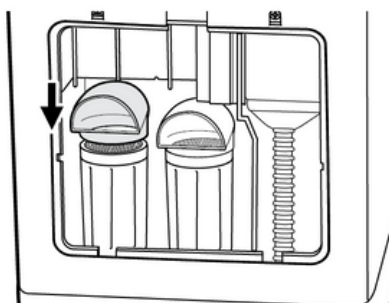

5. Remove plastic from filter caps and install on top of filters.

Detailed instructions: Place the circle-shaped openings on top of the filters, ensuring that the half-moon-shaped opening faces out toward the back of the unit.



6. Replace back panel on unit.

Detailed instructions: Place the back panel so that the two bottom tabs fit into the grooves lining the bottom of the unit's back cavity. Push the back panel into the unit's back cavity until the panel's top fits into the unit groove. Press the sides of the back panel until it snaps into place in the unit's back cavity.

RUNNING A CYCLE

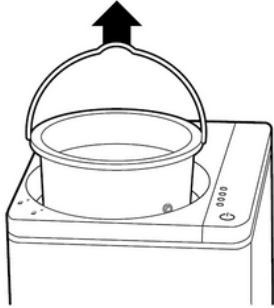

1. Remove bucket*

*While you can add food waste to your bucket when it is inside the FoodCycler™, we do not advise this as it risks food waste falling outside of the bucket and into the unit. This can cause damage to internal components.

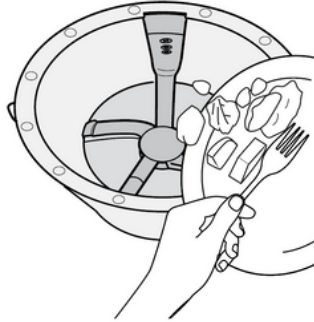

2. Add food waste to bucket

*For a detailed list of the items which can be processed by the FoodCycler™, see page 8.

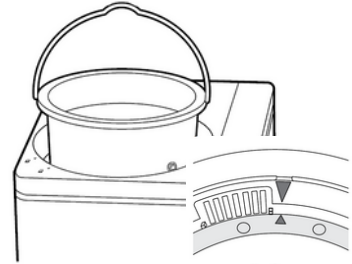

3. Add bucket to unit, aligning the placement arrow on the upper lid of the bucket with the placement arrow at the back of the unit cavity. If the bucket does not seem to fit into the unit, turn the bucket's bottom bolt slightly and then re-insert the bucket.

*Remove internal bucket stickers before using.

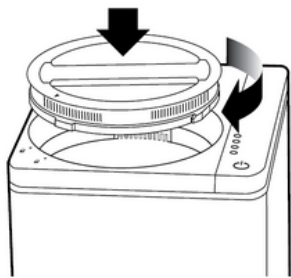

4. Close unit lid, fitting unit lid into cavity with arrow aligned to unlocked. Turn lid so that arrow aligns with the locked symbol on the unit body.

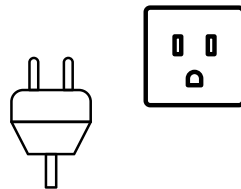

5. Plug unit into outlet.

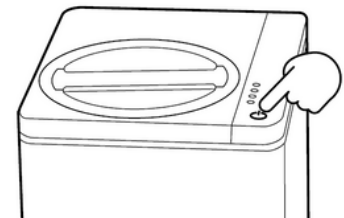

6. Press the Start button once to Power on unit, and again to start cycle. If power light is already on (blue) only press the power button once to start cycle.

ADDITIONAL NOTES ON RUNNING A CYCLE

1) Always ensure that no food waste falls outside of the bucket and into the unit. This may cause damage to the motor and other internal components. We recommend removing the bucket from the unit prior to adding food waste to the bucket. Keep the bucket on your counter or kitchen table and fill it up with food waste throughout the day/week until ready to start a cycle.

2) Do not overload your bucket. The bucket has a fill-line around the interior of the bucket. Do not add food waste above this line. Do not pack down food waste. Overloading the bucket might cause a jam.

3) If you find that you have more waste to add to your cycle while the unit is running, you can use your unit's Pause feature. "Pause" your unit in "Drying" cycle only; this should reduce the chance that your food waste will not be completely dry by the end of the cycle.

In most cases, the volume of your bucket's contents will be reduced by 50% within the first 30-60 mins of your cycle.

Note: Pausing the unit to add more food waste might impact the accuracy of cycle time calculation, which will extend the overall cycle period (though the cycle will never last longer than 8 hours). The by-product may not be fully processed by the end of the cycle. In this case, you may want to run the unit a second time to completely dehydrate the bucket contents.

REPLACING YOUR CARBON FILTERS

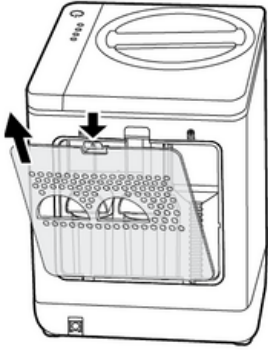

1. Open unit's back panel.



2. Remove filter caps.

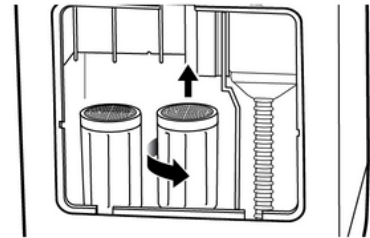

3. Remove used filters, turning counterclockwise.

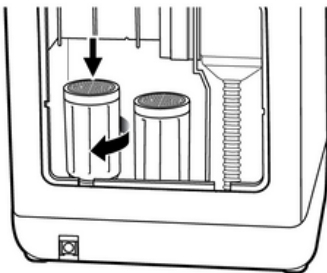

4. Remove new filters from packaging and install in unit, turning clockwise.

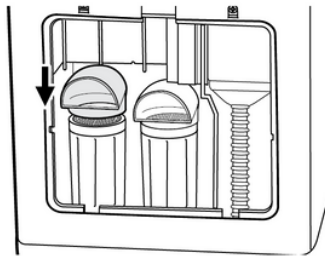

5. Replace filter caps on top of new filters.

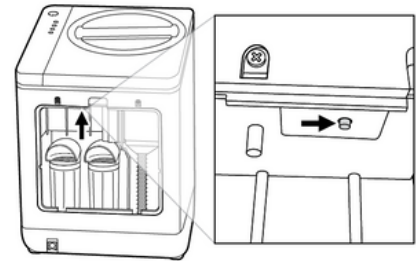

6. Reset filter light.

Detailed instructions:
To turn off the Change Filter light (Reset), feel along the upper, inner lip of the unit back cavity (where, if the unit's back panel were in place, a white Filter Reset arrow would point). Press and hold the small round button until you hear a beep. The Change Filter Light should go off. Refer to picture instruction above.

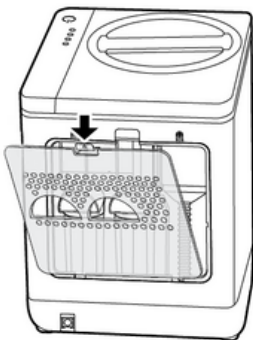

7. Replace the unit's back panel.

WHAT CAN BE CYCLED?

YES



Most vegetable & fruit scraps



Meat, tofu, poultry & fish



Poultry & fish bones



Coffee grinds (incl. filters), tea leaves & teabags

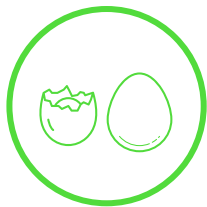

Eggs & eggshells



Avocado pits



Shellfish (incl. shells)



CUT UP PRIOR



Fibrous herbs



Corn cobs & husks



Whole fruits and vegetables



Celery, asparagus & other fibrous plants



A small amount of paper towel/tissue

SMALL AMOUNTS



Sauces, dressings & gravies



Starches (bread, cake, rice)



Dairy products



Jellies & jams, puddings



Starches (bread, cake, rice)

NO



Cardboard



Candy & gum



Most "compostable" plastics



Pineapple leaves

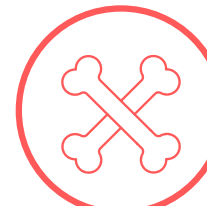

Beef, pork & lamb bones



Oils & fats



Most "compostable" coffee pods



Hard pits (incl. peach, nectarine, apricot, lychee & mango)

USING YOUR BY-PRODUCT IN THE GARDEN

Using an intuitive three-phase cycle, the FoodCycler™ pulverizes and aerates nearly all types of food waste. Agitators quietly turn inside the grinding bucket, reducing food waste volume by up to 90%. Simultaneously, the unit aerates and heats the bucket contents, leaving only a small amount of dry biomass.

While the by-product does not have the same microbial or bacterial qualities as traditional compost, it is still rich in the important nutrients your garden soil requires to thrive. The by-product is scientifically proven to be beneficial for optimal vegetation growth.

FoodCycler™ is a convenient, compact and energy efficient compost alternative. Traditional compost, and composting alternatives (such as vermicompost systems, bokashi and compost tumblers) can take weeks, if not months, to transform food waste into a garden-ready supplement that is high in various micro and macro nutrients, as well as crucial organic biomatter. Because of the intense aeration, heating and pulverization of the unit's full cycle, this process is accelerated to complete within 4-8 hours. Cycling also ensures that meat, dairy and even some bones and processed foods can be added to the cycle. The level of heat emitted by the unit during the cycle is sufficient to completely eliminate all bacteria and potential pathogens - even weed seeds - allowing the by-product to be used safely, and stored indefinitely. The resulting biomass can also be used in the garden as a fertilizer or soil conditioner. See following page for details on incorporating the by-product into your garden soil.



THE FOOD CYCLER™ TIME - LINE



THROUGHOUT
THE DAY

Add food scraps & leftovers throughout the day, or until your bucket is full.

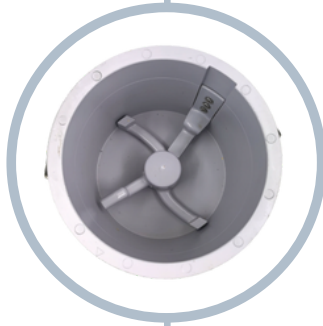

4-8 HOURS

The FoodCycling process takes approximately 4 to 8 hours to fully break down your food into "foodilizer."



1-4 WEEKS

For the absolute best results, add your "foodilizer" to the garden 4 weeks prior to planting. This will allow your by-product to break down in the soil and nourish the soil's existing microbes.

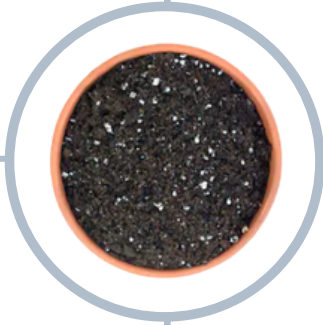

1:10 RATIO

Mix foodilizer in with your soil at a minimum ratio of 1 part by-product to minimum of 10 parts soil (1:15 if your cycle contains meat products)



FAQ

1. Where should I store my unit?

The FoodCycler™ can be run in just about any area indoors that has a power outlet and sufficient space (including basements and heated garages).

- Keep the unit at least 6" from all walls and surfaces to ensure proper ventilation of any steam emissions.
- Ensure that the unit is sitting on a flat, dry surface.
- Do not store the unit next to heaters and kitchen appliances which generate significant heat.
- Do not store the FoodCycler outdoors, or in any place where it is likely to get wet or subjected to below freezing temperatures.

2. What can I process in the FoodCycler™?

Like any healthy diet, the FoodCycler™ performs best when fed a wide variety of foods. To ensure optimal food waste breakdown, add multiple different types of food waste to every cycle, with heavier foods interspersed with lighter, dryer foods. Avoid high concentrations of the following foods:

- starches (bread, cake, rice, pasta, mashed potatoes, stuffing)
- condiments, dressings, sauces & soups
- nut butters
- jam, jellies, marmalades
- high sugar fruits (grapes, cherries, melon, oranges, bananas, etc.)

The dense, starchy and/or moisture-rich composition of these foods make them difficult to process in large quantities. For a complete guide on what you can and cannot process, please see page 7.

Prior to cycling, chop up items with a high fibre content, such as parsley and asparagus, as these items can easily wrap around the bucket's grinding arm and cause a jam.

If a jam occurs, the unit will stop processing and switch to self-protection mode (flashing Drying light). The items causing the jam will need to be removed from the bucket prior to restarting the cycle.

3. What you shouldn't put into FoodCycler?

Do not attempt to cycle anything other than organic wastes in your FoodCycler™ (such as glass, metal or wood). Likewise, do not cycle hard bones (such as pork, lamb or beef bones), pits,

candy, gum, nuts or hard shells: these materials may cause serious damage to the bucket, and/or cause a motor overload. Do not add oil, flammable materials or compounds to the unit.

Note: If a unit or bucket is damaged from cycling, or coming into contact with, the materials listed above, the associated warranties will be considered void, as the inclusion of these materials goes beyond the reasonable use of the unit.

4. Can I store unprocessed food waste in the unit?

We do not recommend leaving unprocessed food waste in the unit for long periods of time. The carbon filters are only able to wick away odours during processing. Leaving decomposing organic matter in the enclosed unit will generate odours, methane gas and might attract fruit flies and/or other pests.

5. What do I do with my byproduct (or “foodilizer”)?

- The unit’s by-product can be used as a soil amendment, or homemade fertilizer. For best results, we recommend adding the by-product to the soil at a ratio of 1 part fertilizer to 10 parts soil. For cycles with an abundance of animal protein (meat, dairy, etc), we recommend increasing that ratio to 1 part fertilizer to 15 parts soil. We also recommend waiting a minimum one week (4 weeks for best results) following soil application before planting seeds or transplanting plants to the newly fertilized soil. Further, the healthier your food waste, the healthier your garden! Foods high in fat, oil, sodium or sugar may not produce optimal results.
- Do not add the by-product directly to the soil surface. This will not feed the soil sufficiently, and the by-product will absorb moisture, which will increase the likelihood that your soil amendment will mold and/or attract unwanted critters to your yard or garden.
- You can also throw it into your green bin or garbage can. Adding the by-product to your household trash is still preferable to throwing in unprocessed food waste, as the by-product will take up less space in landfills and will generate fewer transport emissions once collected (being reduced in weight and volume).

6. How do I extend the life of my filters?

The filter indicator is to remind you to replace your filters every 3-6 months (depending on use) or approximately 500 cycle hours (whichever comes first). The filter indicator is merely a recommendation, however, as the best test of your unit filters is cycle odour. The filter life depends on the quality and quantity of the use of the unit.

- Running a cycle with only citrus rinds (lemons, orange, etc), will help mitigate filter odours.

- We recommend shutting the FoodCycler™ off before leaving your home for an extended period of time. You may also unplug the unit from the wall prior to any trips away from home. Leaving the unit in Active mode (Start button lit up) will also consume the life of the filters.
- Including coffee grounds in your regular cycles can help mitigate odours, and can also help to keep your bucket clean!

7. How do I keep my bucket clean?

The bucket is designed to self-clean with every cycle. It is normal to have a residue in the base and sides of the bucket after some cycles. Simply empty the contents of the finished cycle, ensuring the internal grinding arm can fully rotate, and fill the bucket for the next cycle. If a jam occurs and you are not able to rotate the internal grinding arm, remove contents and manually soak the bucket with boiling water and mild soap overnight, to loosen the blockage.

8. I'm hearing "clunking"/squeaking sounds during my cycle - is this normal?

Noises during the cycle are perfectly normal. While the majority of cycles are quiet, particularly dense, fibrous or moisture-rich food wastes in a cycle can cause the bucket to make sounds as it processes food waste.

INDICATOR LIGHTS GUIDE

LED LIGHTS



CHANGE FILTER

The Change Filter light indicates that filter replacement is due every 3-4 months, depending on use. Once you have replaced your filters, reset Change Filter light (it will not go off automatically) - see Filter Reset Instructions. *The filter light is only a guide. If your unit does not smell, your filters do not yet require replacement.



COOLING

The Cooling Cycle (green) is the last mode in your unit's cycle. The Cooling mode is the shortest phase and will end within 30 minutes. The unit will switch automatically to "Standby mode" once this phase is complete.



GRINDING

The Grinding Cycle (green) is the longest cycle mode and can last anywhere between 3-6 hours, depending on bucket contents. Once this cycle is done, the unit will switch automatically to Cooling. (Hearing some "clunking noises" during this phase is normal, see page 13)



DRYING

The unit's Drying Mode (green) can last anywhere between 60-100 mins and will automatically switch to Grinding once this period of time has elapsed.

Note: If this light is flashing, it indicates that the unit is overloaded. The unit will stop running to avoid a motor overload. In the event that you experience a bucket overload, please remove the contents causing the blockage and ensure that the bucket's grinding arm can fully rotate. Once the blockage is removed, resume the cycle.



The Power or Start button (blue) will flash once when the unit is plugged into an outlet, as it enters the "Standby mode." To enter "Active mode" press the button a second time. Active mode allows air circulation within the unit, allowing you to store unprocessed food waste. Press the button a third time to enter the "Drying" cycle (solid blue light and green Drying light activated).

Pressing the Power button or opening the lid when the unit is processing will pause the cycle. If you would like to add more food waste to the current cycle (only available during Drying), you may continue from where you left off by locking the lid and pressing the Start button once again, as you did when you first started the cycle. The unit will resume processing. Press and hold the Start button for 3 seconds to re-enter "Standby Mode."

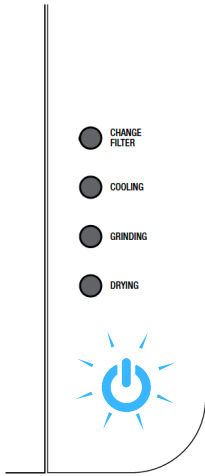

FLASHING POWER LIGHT

Indicates unit lid is open/has come unlatched OR that user has paused the cycle.

Ensure lid is closed and in "locked" position and that the unit is not paused. If food waste is preventing lid from closing, remove enough food waste from bucket to allow lid to close and lock. If lid is secured and locked, and the light continues flashing, reach out to the FoodCycler™ Customer Care Team.

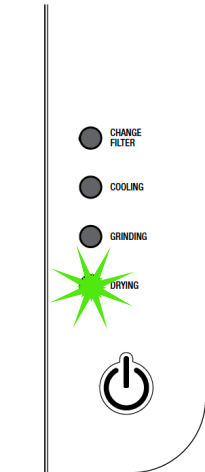

FLASHING DRYING LIGHT (AND BEEPING)

A flashing Drying light indicates the unit is overloaded. The unit will stop running to avoid a motor overload. In the event you experience a bucket overload, simply remove the blockage, ensure the bucket's grinding arm can fully rotate. Resume cycle.

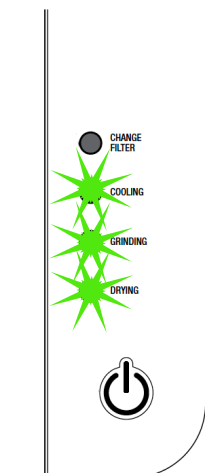

ALL CYCLE LIGHTS FLASHING TOGETHER OR GRINDING/COOLING LIGHT FLASHING

Indicates internal components malfunction. Stop using unit and reach out to the FoodCycler™ Customer Care Team.

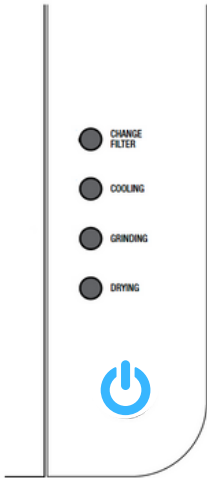

STUCK IN POWER MODE (NOT RUNNING)

This may indicate that the unit cycle has not been initiated by the user.

If the unit does not proceed from the Start/Standby mode (Power light on), ensure that the unit has been powered on correctly:

1. Unit plugged in.
2. User presses Power/Start button once to turn on unit.
3. User presses Power/Start button a second time to start cycle.

If the user has done this and the unit still does not proceed from Power mode, attempt a manual reset (see below).

If the manual reset is unsuccessful, reach out to the FoodCycler™ Customer Care Team.

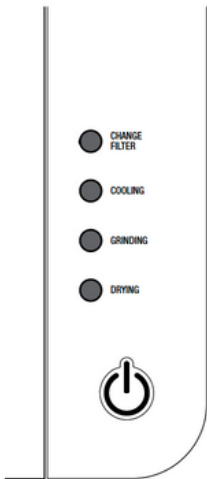

NO POWER

If the unit has no power (no lights or sounds at all) when plugged into an outlet and user attempts to power-on machine, reach out to the FoodCycler™ Customer Care Team.

TROUBLESHOOTING GUIDE

MANUAL RESET INSTRUCTIONS

1. Plug in your unit.
2. Insert bucket in unit, secure the unit lid to the "locked" position,
3. Press down on the Start button for upwards of 3 seconds until you hear a sequence of X3 beeps. Release your finger from the button, the unit will shut off
4. Unplug the unit & wait 2 minutes
5. Plug your unit back in & leave it for 20 seconds
6. Press and release Power/Start button once, if nothing happens, press and release the power/start button a second time.



FOR MORE INFORMATION

Please visit www.foodcyclr.com
info@foodcyclr.com



@TheFoodCycler